



Teo Technologies, Inc.
11609 49th Place West
Mukilteo, WA 98275-4255
(800) 524-0024 (425) 349-1000
Fax (425) 349-1010
www.teotech.com

IP Phone 4104

Installation Instructions



Teo IP Phone 4104 Installation Instructions

© 2014 Teo Technologies Inc. All rights reserved.

Contents

Introduction	5
General Features	5
Controls and Indicators	6
Installation	9
Connecting the Phone	9
Routing the Cords.....	10
Adjusting the Telephone Angle	11
Wall Mounting	12
Labeling Keys.....	13
Configure the Set.....	14
Installation Options	19
Installation Options Menu	19
IP Addresses	20
SIP Configuration.....	25
Quality of Service	30
Configuring Keys	31
Configuring the Speakerphone.....	40
Call Timeout Options.....	41
Installation PIN.....	42
Reset to Factory Default Settings	43
Updates	44
PC Port.....	47
Security Options	47
Viewing the Error Log	48
Administration Options	49
Administration Options Menu	49
Local Inspect	50
Version	51
Test.....	52
Diagnostic Displays	54
Restarting the Phone	56
Troubleshooting	57
Power-up & Connection Troubleshooting.....	57
Call Control Troubleshooting.....	58
Diagnostic Troubleshooting.....	59
Appendix A Setup Menu Tree	63
Appendix B Service and Warranty	71
Appendix C Specifications.....	73
Appendix D Regulatory Statements	75

Teo IP Phone 4104 Installation Instructions

Introduction

For operation instructions and user setup options, please refer to the IP Phone 4104 User Guide, doc. #14-280205.

General Features

The **Teo Model 4104 IP Phone** is an easy to use multiline terminal that provides sophisticated services over managed IP networks running the Session Initiation Protocol (SIP). The telephone includes a built-in 10/100BaseT switch to allow daisy-chain connection of a PC workstation without additional equipment.

Features of the 4104 include:

- 100-entry Call Log for Unanswered, Answered, and Outgoing Calls
- Call Timer
- Last Number Redial
- Speed Dial
- Pre-Dialing
- Direct Station Select
- 36-entry Call Directory
- Voice Mail Access Key
- Message Waiting Indication
- Backlit Graphic LCD Display
- Ringing Control for Shared Lines
- Flexible Ringing Options
- Desktop or Wall Mounting
- Integrated Speakerphone
- Call Monitoring
- Handset or Headset Operation
- Headset Activation Key
- Dedicated Headset Jack
- Integrated 10/100BaseT Switch
- 802.3af Power over Ethernet or Local Power

Various features may not be available with some SIP services.

Controls and Indicators



- 1) **Display** – shows the call state, caller ID, dialed digits, network call control messages, elapsed time during calls, the date and time of day, and softkey options.

The viewing angle is primarily set by changing the base/mounting bracket angle (page 11). Display contrast can be adjusted by a menu selection.

- 2) **Line Keys** – used for Primary Line Appearances.

Line Appearance Key Indicator	Line State
OFF	Idle (On-Hook)
Steady Green	In Use (Off-Hook)
Winking Green	On Hold
Flashing Green	Ringing

- 3) **Multifunction Keys** – used for Additional Line Appearance, Direct Station Selection/ Busy Lamp Field (DSS/BLF), Feature, or Speed Dial keys. The optional 8030X Button Expansion Module provides 30 additional multifunction keys.

Red and green indicators on the keys show line appearance, DSS/BLF and feature status.

DSS/BLF Key Indicator	Monitored Station State
OFF	Available (On-Hook)
Steady Red / Green	Other Presence State* (On-Hook)
Steady Red	On The Phone (Off Hook)
Flashing Green	Ringing

* Note: If your phone is connected to a Teo UC System, steady red/green is used to indicate Busy, Away, Not Available, Do Not Disturb, On Holiday, On Vacation, After Hours, or Call Forward presence states.

Feature Key Indicator	Feature State
OFF	Deactivated
Steady Red	Activated

- 4) **Softkeys** – select the function displayed above the key on the bottom line of the display.
- 5) **Navigation (Arrow) Keys** – navigate within menus. In editing modes, the ► key moves the cursor one position to the right and the ◀ key moves the cursor one position to the left. The ▲ and ▼ keys are used to shift between pages on multi-page screens. The OK key exits the current menu, saves any changes made, and returns to the previous menu options.
- 6) **Message Waiting Indicator** – a bright red indicator is lit when messages are waiting, controlled by the network.
- 7) **VOICE MAIL Key** – accesses network voice mail services.
- 8) **MENU Key** – enters and exits Setup Mode.
- 9) **LOG Key** – displays Call Log options.
- 10) **DIRECTORY Key** – displays the Call Directory.
- 11) **INFO Key** – displays version and configuration information about the 4104 and installed options.
- 12) **MUTE Key** – mutes the microphone when using the speakerphone or handset/headset. A red indicator on the key is lit when mute is active.
- 13) **SPEAKER Key** – activates the speakerphone or Call Monitoring (if enabled by your installer). A green indicator on the key is lit when the speakerphone or Call Monitoring is in use.
- 14) **HEADSET Key** – activates the headset. A green indicator is lit when the headset is in use.
- 15) **VOLUME Key** – adjusts the receiver/speaker volume when on a call; adjusts the ringer volume when on-hook.
- 16) **Dial Pad** – dials telephone numbers, and sends DTMF tones to external equipment such as voice mail systems. The dial pad is also used for text and number entry during setup.
- 17) **Microphone** – used for hands-free (speakerphone) calling; located under the right front corner of the telephone.

Teo IP Phone 4104 Installation Instructions

- 18) **Handset Jack** – a jack on the underside of the telephone connects to the included handset.
- 19) **Headset Jack** – a jack on the underside of the telephone connects to an optional standard headset.

Installation

Connecting the Phone

Connect the 4104 phone to power, LAN, WAN, and the handset or a headset as shown below.

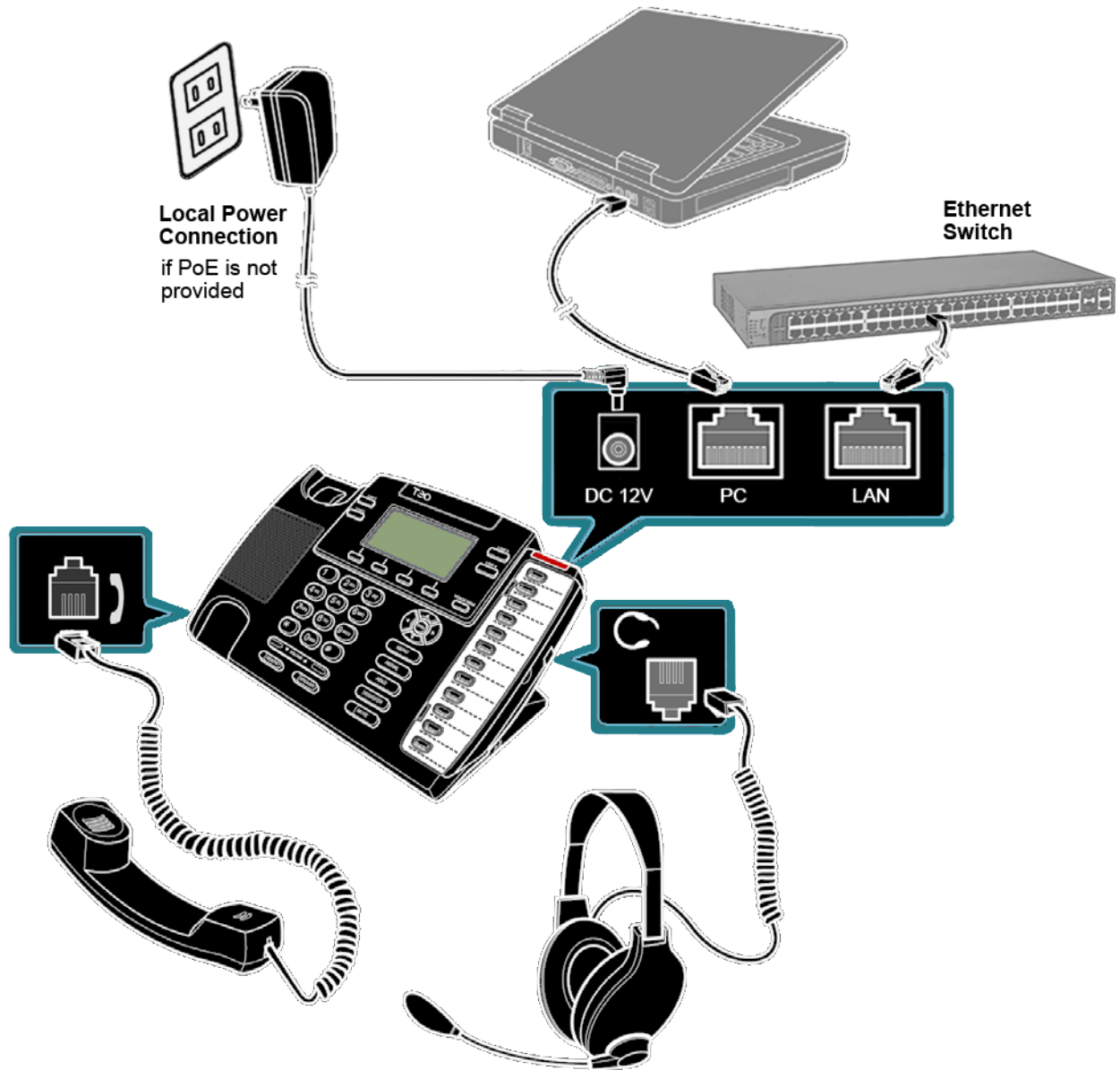

Network Connection

Connect the LAN switch to the phone's **LAN** jack using a Category 5 or better cable. If the network switch provides 802.3af Power over Ethernet (PoE), a local power supply connection is not needed.

Teo IP Phone 4104 Installation Instructions

PC Connection

If you want to use a PC on the same network connection, connect the PC network interface card to the phone's **PC** jack using a Category 5 or better cable.

Handset/Headset

Plug the supplied handset into the Handset jack on the left side of the phone. Plug a compatible headset into the Headset jack on the right side of the phone.

Power

The 4104 is compatible with IEEE 802.3af power over Ethernet cabling, utilizing either power over spare cable pairs (midspan power source) or phantom power (powered switch/hub port). The phone provides an 802.3af PD Class 2 indication to the power sourcing equipment and requires a maximum of 5 watts of power.



Power may also be provided by an optional local power supply (-PWR4 option, Teo model 901054).

Connect power after all other connections are complete. If PoE is not provided, plug the power supply barrel connector into the round **DC 12V** jack on the back of the phone. Connect the power supply to a standard 100-240 VAC, 50-60 Hz power outlet.

Routing the Cords

To place the phone on a desk or flat surface, properly route the cords to ensure uninterrupted connections.

LAN and PC Cords

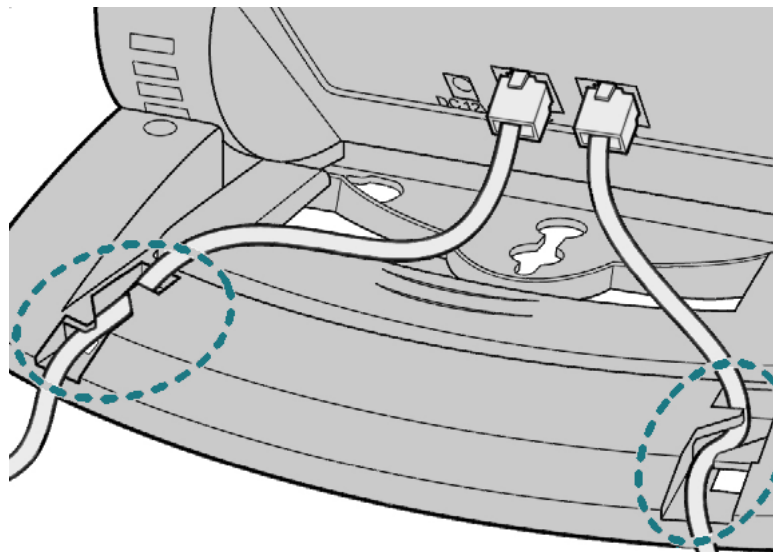

AC Power Adapter Cord

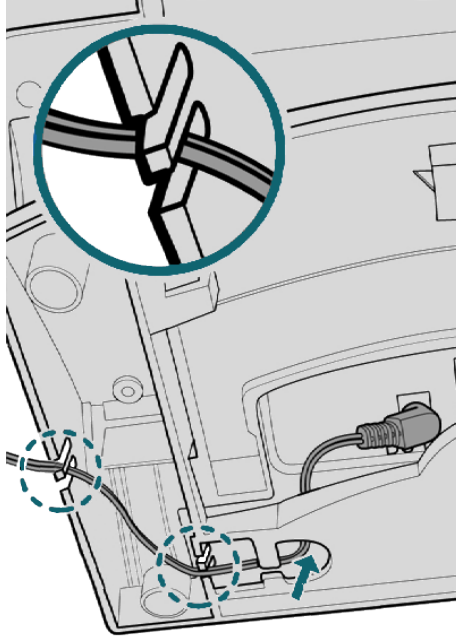

Adjusting the Telephone Angle

- Press down the tab **A** to loosen the base lock.
- As you press the tab, rotate the phone body **B** up or down a slot to adjust tilt.
- Release the tab **A** to lock the base to a slot.

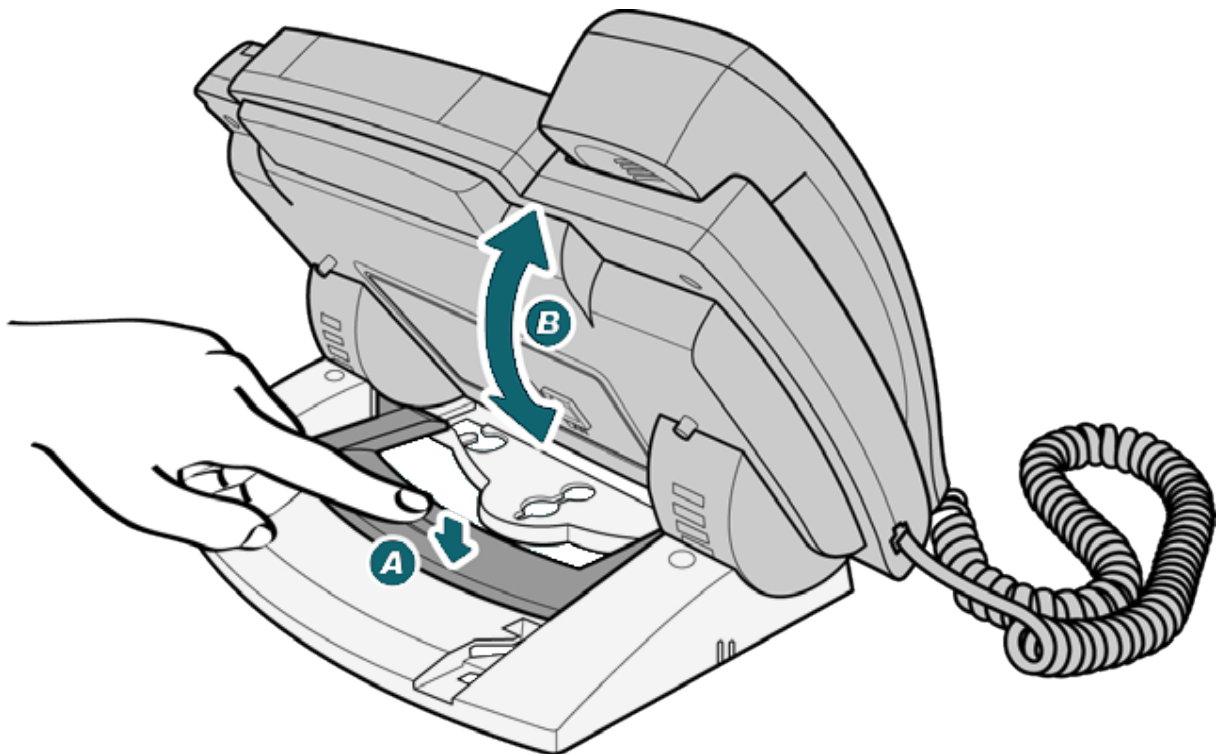

Wall Mounting

To save space, you can directly hang the phone on a wall or wall plate. You need two screws that will fit the keyhole slots.

Note: Wall mounting screws are not supplied with the phone.

- On the wall or a wall plate, drill two holes with a distance of $3\frac{15}{16}$ inches apart. If drilling into drywall only, make sure to install an anchor system for the screws.
- Thread a screw into each hole with each head extending about $\frac{3}{16}$ inch from the wall or wall plate.

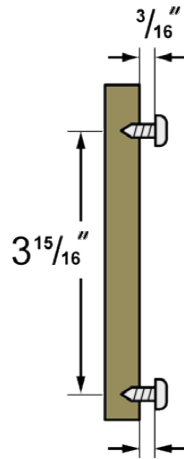

- Connect the AC power adapter, LAN and PC cords (*pages 9-11*) and route them to go under the base.
- Adjust the base so it lays flat on the back of the phone.
- Fasten the base to the back of the phone with the supplied screws.

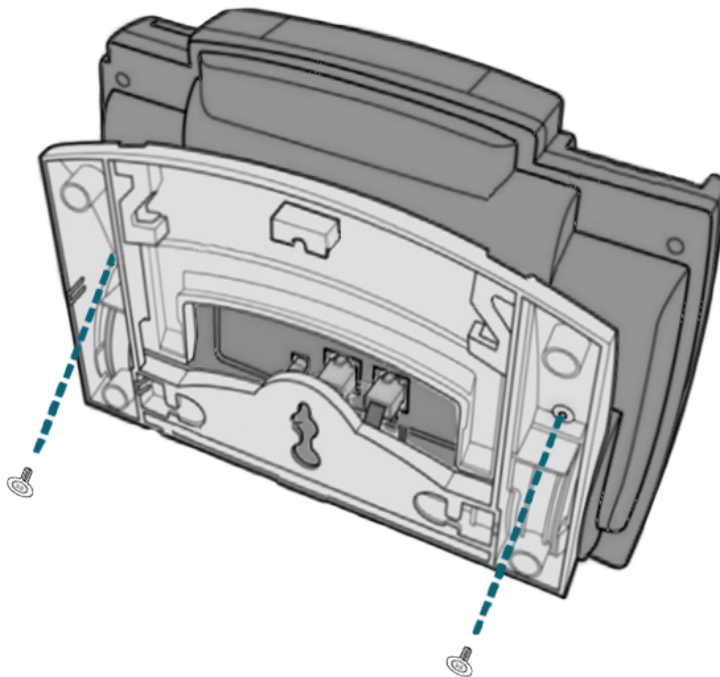

- Align the phone's keyhole slots with the screws and slide the phone downward to secure it.

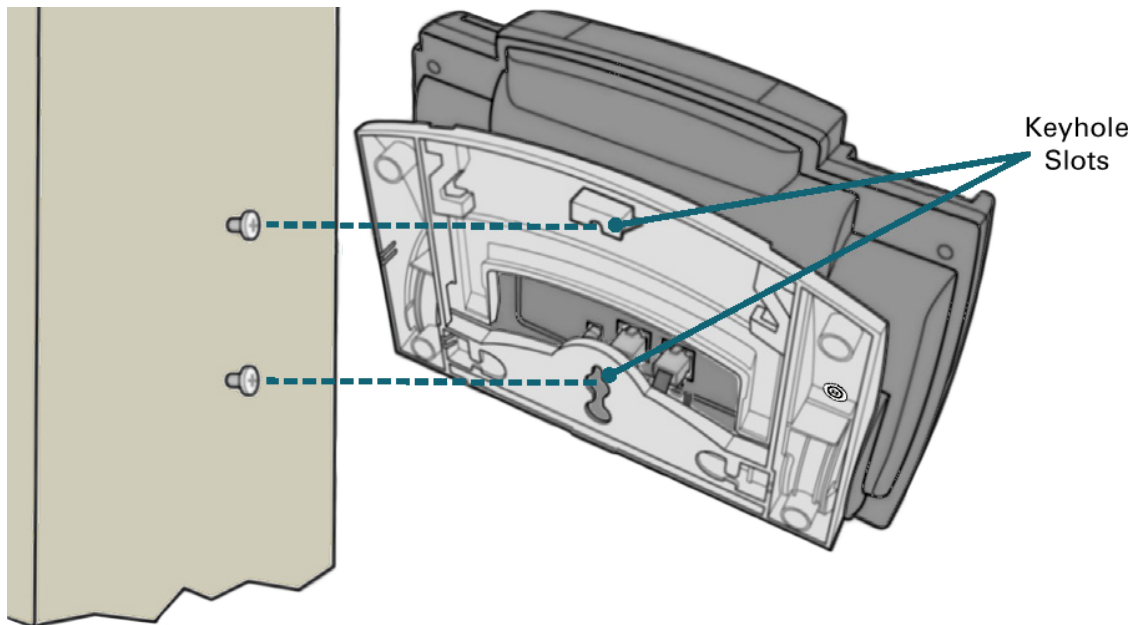

Labeling Keys

The 12 multifunction keys on the right side of the phone can be labeled with the telephone number, feature name, speed dial party name, or other appropriate designation.

Remove the clear label cover by lifting the right side, then write or type on the provided paper label. Replace the paper label and snap the cover into place.

Using Local Inspect to Verify Keys

Local Inspect (*page 50*) allows you to identify the line appearance or feature assignment of each configured key, directory number bearer capabilities, and the feature indicator assignment for the Message Waiting Indicator.

Configure the Set

Appropriate IP addresses, configuration attributes, and passwords may be provided by various network servers, providing automatic configuration of the phone.

You will be prompted for any required setup information that cannot be set automatically.

Entering Alphanumeric Characters

Character strings are entered with the dial pad. Three entry modes are available for most fields – numeric, upper case, and lower case.

-  The entry mode default is numeric, as indicated by '123' in the display above the 3rd softkey. To enter uppercase (ABC) or lowercase (abc) characters, press the softkey until the desired label entry mode is shown.

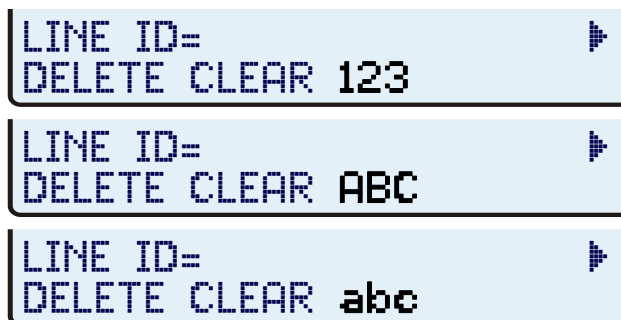

Numeric Characters

Press a dial pad key to enter a digit. The cursor will immediately advance to the next character position.

-  To enter a * or a period, press the * key repeatedly until the desired character appears.

After a short delay, the cursor will advance to the next character position. You can also immediately press a dial pad key or the Right Arrow key to enter the next character without waiting for the delay.

Upper or Lower Case Characters

-  Letters are entered with dial pad keys 2-9. Press a key repeatedly until the desired character appears.

After a short delay, the cursor will advance to the next character position. You can also immediately press a dial pad key or the Right Arrow key to enter the next character without waiting for the delay.

Punctuation and Special Characters



To enter punctuation or special characters, press the * key when in upper or lower case mode to show available characters in the top line of the display. Press the * key repeatedly until the cursor is on the desired character.

After a short delay, the character will be added to the dial string and the cursor will advance to the next character position. You can also immediately press a dial pad key to enter the next character without waiting for the delay.

```

.:+@_-\,;*'"()o^=?!$%&
DELETE CLEAR ABC

```



To enter a # or a space, press the # key repeatedly until the desired character appears.

Editing Character Strings

Press the Left Arrow or Right Arrow key to move the cursor.

Press a dial pad key to enter a character to the left of the cursor, or select DELETE to delete the character under the cursor.

Select CLEAR to remove all characters.

Teo IP Phone 4104 Installation Instructions

Initialization

With the application of power, the phone's operating software is loaded into internal memory. During this interval, the Message Waiting Indicator will be illuminated. Upon completion, the display will show the current software version.



```
INITIALIZING...  
APP VERSION 06.04.16
```

The display will show progress messages while establishing the communication layers.

Many configuration settings can be set automatically by a DHCP server and telephone update server. DHCP should be used if available; it is enabled by default.

If DHCP and update servers are available and configured properly, the phone will prompt for a Line ID and SIP Password the first time that the phone is connected to the network. You may also be prompted for an authentication ID if required by the system.



```
LINE ID=  
DELETE CLEAR 123
```

- Enter the appropriate Line ID (phone) number, and then press the **OK** key. This would typically be the phone number used for station-to-station calls.



```
AUTH ID=  
DELETE CLEAR 123
```

- If prompted, enter the appropriate authentication ID number, and then press the **OK** key. Leave this entry blank if no authentication ID is required.



```
SIP PSWD=  
DELETE CLEAR 123
```

- Enter the appropriate password, and then press the **OK** key. Leave this entry blank if no password is required.
- If the update server protocol and IP address are not supplied by DHCP, configure these items as shown on the following page.

During the registration process, the line key indicators will flash red. When lines are registered with the proxy server, the indicators will turn solid green momentarily, and then go out. The following status message will be displayed when registration is complete.



```
ALL LINES REGISTERED
```

The idle display will then appear, indicating that the phone is ready for use.

Initialization without DHCP Server

The DHCP (Dynamic Host Configuration Protocol) server automatically assigns the telephone address, server addresses, and subnet mask. If DHCP is not available, or is not provisioned with all of these parameters, they must be entered manually.

The following display will be shown while the phone attempts to connect to a DHCP server.

```
CHECKING DHCP
DISABLE
```

- If no DHCP server is available, select DISABLE to use static addressing.

```
IP4 ADDR=000.000.000.000
EDIT
```

- Select EDIT.

```
IP4 ADDR=000.000.000.000
DELETE CLEAR PING4
```

- Select CLEAR to remove the displayed IP address. Enter the phone's IP address with the dial pad; use the * key to enter a ".". Press the **OK** key when finished.
- Enter the required subnet mask and gateway IP address when prompted; press the **OK** key after each entry.

Next, the phone will prompt for an update server protocol and IP address.

```
SELECT UPDATE SERVER: ▶
TEO  TFTP  HTTP  HTTPS
```

```
SELECT UPDATE SERVER: ▶
NONE
```

- Select a protocol, and then enter the update server IP address. Press the **OK** key when finished. If no update server is available, select NONE.

The phone then will prompt for the Line ID, authentication ID, and SIP password as shown on the previous page.

Teo IP Phone 4104 Installation Instructions

Installation Options

The following options are available from the Installation Options menu:

- IP Addresses
- SIP Options
- Quality of Service *
- Keys
- Call Timeouts
- Installation PIN
- Reset to Default Settings
- Configuration Updates *
- PC Port
- Security Options
- Error Log

* Noted options are explained briefly in this manual.
For details, refer to the *IP Telephone Network Administration Guide*.

Installation Options Menu

You can enter the Installation Options menu when the phone is idle.

 MENU

Press the **MENU** key.

```
SETUP MENU
INSTL ADMIN USER
```

 Select **INSTL**.

 5 JKL

The Installation Options menu may be protected by a PIN. Enter your PIN with the dial pad, and then press the **OK** key.

To change or remove the PIN, refer to page 42.

```
ENTER PIN: *****
BKSP CLEAR
```

```
INSTALLATION OPTIONS ➤
IP      SIP      QOS  KEYS
```

 When ◀ or ▶ appears in the upper line of the display, you can press the Left or Right Arrow key to see additional menu selections.

```
INSTALLATION OPTIONS ➤
CALL PIN RESET UPDATE
```

```
INSTALLATION OPTIONS ◀
PCPORT SECRTY LOG
```

Teo IP Phone 4104 Installation Instructions

Some configuration changes only take effect after a phone restart. You may be prompted to allow a restart before you can proceed with changes.

```
RESTART NEEDED: PROCEED?  
YES     NO
```

- Select YES to proceed with editing, or NO to abort and return to the previous menu.

After exiting Setup Mode, you may be prompted to restart the phone. Some changes require a restart.

```
RESTART WITH NEW VALUES?  
YES     NO
```

- Select YES to restart the phone immediately, or NO return to the Setup menu.

IP Addresses

IP address entries are required for the phone, subnet mask, gateway/router, SIP proxy, and optional update and SNTP servers. By default, the phone uses DHCP (Dynamic Host Configuration Protocol) to automatically set the IP addresses and the subnet mask.

The phone can also obtain server addresses, as well as software updates and QoS settings from an update server. Please refer to the [IP Telephone Network Administration Guide](#).

Automatic IP Configuration (DHCP)

IP addresses for the telephone, servers, and subnet mask are normally provided by a DHCP server when the phone starts.

The DHCP server can supply the following addresses:

- Phone IP Address
- Phone Subnet Mask
- Phone Domain Name
- Default Gateway IP Address
- DNS Server IP Address(es)
- SNTP Server IP Address(es)
- Update Server IP Address
- SIP Proxy IP Address(es)

Manual IP Configuration

All IP addresses listed above may be entered as static (fixed) addresses from the phone's Installation Options Menu. When setting up servers and telephones, server names can be entered in place of IP addresses.

Note: You must restart the phone after any IP address changes have been made for the changes to take effect (MENU → ADMIN → ► → RESTART).

- From the Installation Options menu, select IP.
(MENU → INSTL → IP)

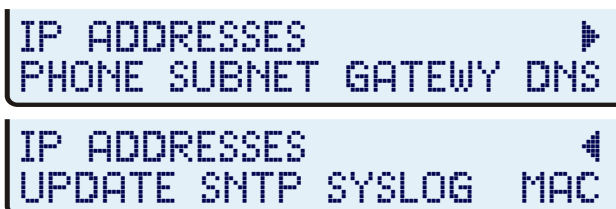

Select the IP address to view or edit.

- PHONE** – IP address of this telephone
- SUBNET** – Subnet mask for telephone IP addresses
- GATEWAY** – Gateway to WAN or Internet
- DNS** – Domain name server
- UPDATE** – Update server
- SNTP** – Time server
- SYSLOG** – Error and QoS logging server
- MAC** – Ethernet MAC address (view only)

Note: To edit the SIP proxy server and SIP registration server IP address, see pages 28–29.

Internet Protocol

The phone supports both IPv4 and IPv6 protocols. The IP address configuration method can be selected independently for the phone, domain name server, update server, SNTP server, and Syslog server.

Phone IP Address

The phone can have an IPv4 address, as well as several IPv6 addresses.



- Select the IP address type that you want to configure.

IPv4



The phone's IPv4 address is normally supplied by DHCP.

Teo IP Phone 4104 Installation Instructions

- To use static addressing for the phone, subnet, and gateway, first select STATIC from the ADDRESS CONFIG OPTIONS - IPv4 menu. (MENU → INSTL → IP → UPDATE → CFG → STATIC) (page 44)

```
IP ADDRESSES
UPDATE SNTP SYSLOG MAC

UPDATE=192.168.1.1
EDIT PING4 CFG

UPDATE ADDR CONFIG=STATIC
DHCP4 STATIC
```

- 5 JKL Enter the phone's new IP address with the dial pad. (MENU → INSTL → IP → PHONE → IPv4 → EDIT)

```
IPv4 ADDR=192.168.1.35
DELETE CLEAR PING4
```

IPv6

```
IPv6 ADDRESS(ES)
LINK GLBL1 ADD
```

- Select LINK to view the local link address.
- If a global address has been automatically configured, GLBL1 will be shown in the menu. Select this option to edit or remove the global address.

```
ADDR=2115:21:3:A:204:8D:
VIEW EDIT REM PING6
```

- Select ADD to add a new global address. The phone can have up to five global addresses.

- 5 JKL Enter the global address with the dial pad.

Other IP Addresses

- After selecting an IP submenu (DNS, UPDATE, SNTP, or SYSLOG), select CFG to change the IP address configuration method to DHCP4 or STATIC.

```
DNS=192.168.1.2
EDIT PING4 CFG

DNS ADDR CONFIG=DHCP4
DHCP4 STATIC
```

-  If you have set the protocol to STATIC, select EDIT to change the address, and then enter the address with the dial pad. The address can be an IP address or fully qualified domain name (FQDN). Select 123 to change between numeric, uppercase alpha and lowercase alpha character entry mode.

```
DNS=192.168.1.2
DELETE CLEAR 123
```

Update Server

In addition to the IP address or FQDN, you can also specify a non-standard port and path name for update files. Enter a colon between the IP address or FQDN and the port number. To enter a colon, select 123 to change to alpha character entry mode (ABC or abc), then press * twice. If the update files are not located in the root directory of the update sever, include a path name to the appropriate subdirectory under the root directory.

```
UPDATE=myserv:9443/teo
DELETE CLEAR 123
```

SNTP Server

In addition to the IP address or FQDN, you can also specify the time offset (in hours) from UTC for your local time zone, and automatically adjust for daylight savings time.

Time Offset

```
SNTP=206.080.111.006
EDIT OPTION PING4 CFG
```

-  Select OPTION.

```
SNTP OPTIONS
OFFSET DSTADJ
```

-  Select OFFSET.

```
CHG AUTO CONFIG? DHCP4
DHCP4                STATIC
```

-  If the above display appears, select an addressing option, then press the **OK** key.



```
TIME OFFSET=-8 HOURS
(-)      (+)
```

-  Select (-) or (+) to change the time offset.



- Press the **OK** key twice when finished.

Teo IP Phone 4104 Installation Instructions

Daylight Savings Time

```
Sntp=206.080.111.006  
EDIT OPTION PING4 CFG
```

 Select OPTION.

```
Sntp OPTIONS  
OFFSET DSTADJ
```

 Select DSTADJ.

```
AUTO DAYLIGHT SAVING=ON  
ON OFF
```

 Select ON to automatically adjust the clock for daylight savings time, or OFF to disable daylight savings time adjustment.

The default setting in the phone starts daylight savings time at 2:00 a.m. on the second Sunday of March, and ends it at 2:00 a.m. on the first Sunday of November. These settings can be customized in the phone's XML configuration file – refer to the [IP Telephone Network Administration Guide](#).

 Press the **OK** key three times when finished.

Syslog Server

A Syslog server can record error logs and QoS statistics sent from activated telephones on the network.

```
Syslog=206.080.123.012  
EDIT OPTION PING4 CFG
```

 Select OPTION, and then choose one of these options:

- NONE** – disable Syslog messages from this telephone
- BASIC** – record telephone error logs
- QoS** – record telephone error logs and QoS statistics

```
Syslog OPTION=BASIC  
NONE BASIC QOS
```

 Press the **OK** key when finished.

Ping Test

```
IP4 ADDR=216.122.043.243
EDIT          PING4
```

-  To test the phone, gateway/router, or server address, select PING4 or PING6 from the device's IP address menu. If you have entered a new phone IP address, the phone must be restarted before ping will work properly. (SETUP → ADMIN → ► → RESTART)

While the phone is pinging the address, the following display will appear.

```
PINGING IP4 ADDRESS...
PRESS ANY KEY TO CANCEL
```

If a response is received, indicating a valid address, "PING4 SUCCESSFUL" or "PING6 SUCCESSFUL" will be displayed.

```
PING4 SUCCESSFUL
PRESS ANY KEY TO EXIT
```

If no response is received, the entered address is invalid. "PING4 FAILED" or "PING6 FAILED" will be displayed.

```
PING4 FAILED
PRESS ANY KEY
```



Press any key to return to the previous menu.

SIP Configuration

The SIP options configure the phone to allow registration with and signaling of SIP Server applications. Please refer to the [IP Telephone Network Administration Guide](#) and the SIP server documentation.

-  From the Installation Options menu, select SIP. (MENU → INSTL → SIP)

```
SIP CONFIGURATION
PHONE PROXY REGSTR MWI
```

-  Select one of the SIP options.

Teo IP Phone 4104 Installation Instructions

- PHONE** – domain name, port, and RTP start port for this telephone
- PROXY** – SIP Proxy server IP address and port
- REGSTR** – registration enable, SIP Registrar server IP address and port
- MWI** – message summary event subscription for Message Waiting Indication

After selecting an option to view or edit, you can begin editing immediately if the phone is not currently registered with the SIP server.

-  If the phone is currently registered, select CHANGE to edit the setting, or press the **OK** key to return to the previous menu (PHONE, PROXY, or REGSTR).

You will be warned that a restart of the phone is required for the changes to take effect. Select YES to continue editing, or NO to return to the previous menu.

PHONE (SIP Phone Configuration)



```
SIP PHONE CONFIGURATION
DOMAIN PORT RTP
```

-  Select one of the displayed options. The current setting will be shown.

DOMAIN (Domain Name or IP Address)



```
DOMAIN=domain.company.c
CHANGE
```

-  Select CHANGE.



```
DOMAIN=domain.company.c
DELETE CLEAR abc
```

-  Enter or edit the domain name or IP address with the dial pad (maximum 128 characters). *Character entry is explained on page 14.*

-  When finished, press the **OK** key to return to the SIP Phone Configuration menu.

PORT

```
SIP PORT=5060
CHANGE
```

 Select CHANGE.



```
SIP PORT=5060
DELETE CLEAR 123
CHANGE
```



Enter or edit the proxy port number with the dial pad (maximum 5 numeric characters). *Character entry is explained on page 14.*



When finished, press the **OK** key to return to the SIP Phone Configuration menu. SIP signaling will use the new port number on the next call or registration attempt.

RTP (RTP Start Port)

```
RTP PORT=16384
CHANGE
```

 Select CHANGE.



```
RTP PORT=16384
DELETE CLEAR 123
CHANGE
```



Enter or edit the RTP start port number with the dial pad (maximum 5 numeric characters). *Character entry is explained on page 14.*



When finished, press the **OK** key twice to return to the SIP Phone Configuration menu. SIP signaling will use the new port number on the next call or registration attempt.

PROXY (SIP Proxy)



```
SIP PROXY CONFIGURATION
ID  PORT
```

 Select one of the displayed options. The current setting will be shown.

Teo IP Phone 4104 Installation Instructions

ID (Fully-Qualified Domain Name or IP Address)

```
PROXY=192.168.72.111
CHANGE
```

 Select CHANGE.

```
PROXY=192.168.72.111
DELETE CLEAR 123
```



Enter or edit the fully-qualified domain name or IP address with the dial pad (maximum 128 characters). *Character entry is explained on page 14.*



When finished, press the **OK** key to return to the SIP Proxy Configuration menu.

PORT

```
PROXY PORT=5060
CHANGE
```

 Select CHANGE.

```
PROXY PORT=5060
DELETE CLEAR 123
```



Enter or edit the proxy port number with the dial pad (maximum 5 numeric characters). *Character entry is explained on page 14.*



When finished, press the **OK** key to return to the SIP Proxy Configuration menu. SIP signaling will use the new proxy port number on the next call or registration attempt.

REGSTR (SIP Registration)

```
SIP REGISTRATION
ENABLE ID PORT
```

 Select one of the displayed options. The current setting will be shown.

ENABLE (Enable or Disable SIP Registration)

```
SIP REG=ENABLED
ENABLE DISABLE
```



Select ENABLE or DISABLE.



When finished, press the **OK** key to return to the SIP Registration menu.

ID (Fully-Qualified Domain Name or IP Address)

```
REG=192.168.72.111
CHANGE
```



Select CHANGE.

```
REG=192.168.72.111
DELETE CLEAR 123
```



Enter or edit the fully-qualified domain name or IP address with the dial pad (maximum 128 characters). *Character entry is explained on page 14.*



When finished, press the **OK** key to return to the SIP Registration menu.

PORT

```
REGISTRAR PORT=5060
CHANGE
```



Select CHANGE.

```
REGISTRAR PORT=5060
DELETE CLEAR 123
```



Enter or edit the proxy port number with the dial pad (maximum 5 numeric characters). *Character entry is explained on page 14.*



When finished, press the **OK** key to return to the SIP Phone Configuration menu. SIP signaling will use the new port number on the next call or registration attempt.

Teo IP Phone 4104 Installation Instructions

MWI (Message Summary Event Subscription for MWI)

This setting determines whether the phone subscribes to message summary events for Message Waiting Indication. This parameter should be set to **OFF** for Cisco voicemail systems.

```
MSG-SUMMARY SUB=ON
OFF
```

- Select OFF or ON. The current setting will be shown.

Quality of Service

Quality of Service (QoS) settings can improve voice performance over a network by prioritizing voice packets.

These settings must be coordinated with other network devices, and should not be changed unless required to correct audio problems. Consult with your network administrator before changing these settings.

- To view or change Quality of Service settings, select QoS from the Installation Options menu.
(**MENU** → **INSTL** → **QoS**)

```
QUALITY OF SERVICE
L2  L3
```

- Select L2 for Layer 2, or L3 for Layer 3.

```
LAYER 2 802.1Q=ON
OFF  PHONE  PC
```

```
LAYER 3 DIFFSERV
VOICE SIGNAL
```

Refer to the [IP Telephone Network Administration Guide](#) for help with setting QoS options.

Configuring Keys

You can assign line appearances, feature activators, and DSS/BLF/Speed Dial numbers to keys, and set up the **VOICE MAIL** and **SPEAKER** keys by using this option.

-  From the Installation Options menu, select KEYS.
(**MENU** → INSTL → KEYS)

The status indicator for each key will indicate the current setting:

- Green** – Line Appearance or DSS/BLF
- Red** – Feature Activator
- Off** – Unused or Speed Dial



SELECT A KEY



- Press the line or multifunction key to be programmed.
The selected key's indicator will alternately flash red and green.



12=UNUSED ▶
LINE FA DSS SPDIAL



12=UNUSED ◀
ACD UNUSED

-  Select LINE (Line Appearance), FA (Feature Activator), DSS (Direct Station Select/Busy Lamp Field), SPDIAL (Speed Dial), ACD (Automatic Call Distribution), or UNUSED from the menu.

Programming procedures for each key type are described below.



- When finished editing keys, press the **OK** key to return to the Installation Options menu or press the **MENU** key to exit Setup Mode.

Teo IP Phone 4104 Installation Instructions

Line Appearance Keys

Line keys are used to place and answer calls. A SIP line can appear on multiple consecutive keys.

Notes: Line keys 1-4 are dedicated for use as the primary line ID of the phone, and cannot be used for any other purpose.

For information about the CODEC, PTIME (packetization time), and JTR (jitter buffer) settings, please refer to the [IP Telephone Network Administration Guide](#).

New Line Key

-  If the key is not currently programmed as a line key, select LINE from the menu.

```
04=UNUSED
LINE   FA   DSS  SPDIAL
```

-  Enter the line ID with the dial pad.
Character entry is explained on page 14.



```
LINE ID=1234
DELETE CLEAR 123
```

-  Press the **OK** key.
The Line Key Options menu will appear. Proceed with editing the key options as explained below.

Edit Existing Line Key

If the selected key is currently programmed as a line key, the display will show the key number and line ID. A range of consecutive key numbers will be shown if the line ID is assigned to multiple keys (a multiple line appearance group).

```
01-03: 4321
EDIT ADD  REMOVE
```

-  Select **ADD** to add the next key to the group. A group can contain up to five keys.
-  Select **REMOVE** to remove the last key from the group.

- Select EDIT to change the settings for the key.

```

LINE KEY OPTIONS  ▶
  ID  NAME AUTHID PSWD

LINE KEY OPTIONS  ◀▶
SHARE CODEC  PTIME  JTR

LINE KEY OPTIONS  ◀
ADD  REMOVE  LABEL  AA

```

- Select NAME.

5 JKL

Enter the caller ID display name with the dial pad, up to 24 characters maximum. Caller ID name display may not be supported by some SIP servers.

```

NAME=Nick Robinson
DELETE CLEAR abc

```

OK

- Press the **OK** key.

Line appearance sharing as described below is for use with Avaya and other systems that support shared lines. Leave the Shared Line setting disabled when connected to a Teo UC system. The share setting is not used for multiple registrations of the same Line ID as the primary line.



- Press the Left or Right Arrow key repeatedly until SHARE is shown in the menu.

The AUTHID (authentication ID) and PSWD (SIP authentication password) may be required for this line, and the codec, ptime, and jitter buffer options may need to be changed; consult your system administrator.



- Select SHARE to control sharing of this line with other telephones.

```

SHARED LINE=DISABLED
ENABLE DISABLE

```



- Select ENABLE to enable sharing, or DISABLE to disable sharing.

OK

- Press the **OK** key.

At other telephones that will share this line, set up a key (not line key 1-4) with the same Line ID, and enable sharing for that key.

Teo IP Phone 4104 Installation Instructions

Auto Answer

A line appearance or group can be configured to automatically answer a call when the phone is idle, if the call's SIP alert-info header matches a predefined string (*up to 10 strings can be defined; refer to the [IP Telephone Network Administration Guide](#)*). Calls can be answered in 2-way speakerphone mode, or with the microphone muted. Applications for the Auto Answer feature include paging, intercom calls, ACD calls, and dialing or answering from computer-based applications.

An Auto Answer enable/disable softkey is available for the user if Auto Answer has been enabled for any line appearance. When disabled, auto answer calls will ring normally with a distinctive ring pattern.

- Select AA. The current Auto Answer state is shown in the top line of the display.

```
AUTO ANSWER=DISABLE
ENABLE
```

- Select ENABLE to enable Auto Answer for this line or group.

```
AUTO ANSWER=ENABLE/2WAY
DISABLE                MUTE
```

- To change to Mute or 2-Way mode, press the rightmost softkey. Select DISABLE to disable Auto Answer.

```
AUTO ANSWER=ENABLE/MUTE
DISABLE                2WAY
```

Label *(Line Appearance Key 1 only)*

Note: The label entry for Line Appearance Key 1 is shown in large text when the phone is idle. Label entries for any other line appearance keys are not used.

- To customize the idle screen display, select LABEL.

```
LBL=4321
DELETE CLEAR ABC
```

- The line ID is shown by default. To change the label, select CLEAR to remove the existing label, or press the Left or Right Arrow key to move the cursor position for editing. DELETE removes the character under the cursor.

- 5 JKL Using the dial pad, enter a label, 18 characters max. (*page 14*). Fewer than 18 characters may be shown on the idle display, depending on character width.

- OK Press the **OK** key to return to key selection.

Feature Activator Keys

Feature Activators are assigned to keys from a list of presets. Default presets are shown in the table below; they may be customized by your network administrator.

Dial Pad Key	Predefined Label	Default Multifunction Key Assignment
1	Call Forward	Key 15
2	Do Not Disturb	Key 16
3	Directed Call Pickup	–
4	Presence	–
5	<i>unused</i>	–
6	<i>unused</i>	–
7	<i>unused</i>	–
8	<i>unused</i>	–
9	<i>unused</i>	–
0	<i>unused</i>	–
*	<i>unused</i>	–
#	<i>unused</i>	–

5 JKL

Use the dial pad to select one of the available presets.

```
3=DIR CALL PICKUP
USE DIALPAD KEYS
```

Note: Call Forward and Presence keys are mutually exclusive; only one of these keys can be configured on a phone. The Presence key is used with the Teo UC System and includes a Call Forward option.

OK

Press the **OK** key to return to key selection.

Teo IP Phone 4104 Installation Instructions

DSS/BLF Keys

DSS/BLF keys are Line Appearance keys that have been programmed with speed dial numbers to provide Direct Station Selection. The line assigned to a DSS/BLF key appears on one or more additional telephones. When the line indicator shows idle or busy, a DSS/BLF key behaves like a Speed Dial key, it calls a station. When the line assigned to the DSS/BLF key is blinking green at your phone, pressing the DSS/BLF key will answer the call.

Enter the Line ID, Caller ID Name, Authentication ID, and Authentication Password as described for standard line keys. For Caller ID Name, Authentication ID and Authentication Password, check with your system administrator.

```
DSS/BLF KEY OPTIONS  ▸
  ID  NAME  AUTHID PSWD
```

```
DSS/BLF KEY OPTIONS  ◀
  TYPE  DSS#
```

 Select TYPE.

```
EVENT TYPE=PRESENCE
PRES DIALOG DLGSLA
```

 Select the event type that is supported by the SIP server:

- PRES** – (Event: presence), for use with the Teo UC System
- DIALOG** – (Event: dialog)
- DLGSLA** – (Event: dialog;sla)

 Press the **OK** key.

The Line ID followed by a # character is automatically entered as the speed dial number.

```
DSS SPDIAL=54321#
DELETE PAUSE 123
```

 If you need to edit the dial string, select DSS#, and then enter the number to dial with the dial pad.



Character entry is explained on page 14.

Immediate or Editable Dialing

For one-touch dialing, enter a # character at the end of the dial string. The string will be dialed immediately when the DSS/BLF key is pressed.

A DSS/BLF key can be used in conjunction with manual dialing. If you want to enter more digits after pressing the DSS/BLF key, or edit the dial string before dialing, do not include the # character.



When all digits have been entered, press the **OK** key.

Speed Dial Keys

Unused keys not assigned for line appearances or feature activators may be used as Speed Dial keys. Dial strings can include network feature activator codes, to simplify the use of features such as Directed Call Pickup and Call Forwarding. Speed Dial keys may also be programmed from the User Options menu.



Enter speed dial digits with the dial pad.
Character entry is explained on page 14.

```
NUMBER=5553491000
DELETE PAUSE 123
```

"Smart" Pauses



Pauses are entered with the PAUSE softkey, and are shown in the display as a P character. The first pause in a dial string will delay dialing until the call is answered; additional pauses delay dialing for one second per pause. Enter multiple pauses to increase the delay time. You can use a smart pause to automatically enter a PIN code after the called number answers.

```
NUMBER=5553491000P1234#
DELETE PAUSE 123
```

Immediate or Editable Dialing

For one-touch dialing, enter a # character at the end of the dial string. The string will be dialed immediately when the Speed Dial key is pressed.

A Speed Dial key can be used in conjunction with manual dialing. If you want to enter more digits after pressing the Speed Dial key, or edit the dial string before dialing, do not include the # character.



When all digits have been entered, press the **OK** key.

Teo IP Phone 4104 Installation Instructions

ACD Keys

ACD keys are used to log in to or log out of a Sylantro ACD (Automatic Call Distribution) group.

ACD requires two keys for Login and Activate functions. If the selected key is not followed by an unused key, you will receive the following warning.

```
FEATURE REQUIRES TWO  
ADJACENT UNUSED KEYS
```

Select another key to continue.

```
ACD KEY OPTIONS  
ID
```

5 JKL

Enter the ACD group number.
Character entry is explained on page 14.

OK

Press the **OK** key.

Unused Keys



After selecting a key, press the Left or Right Arrow key until UNUSED is shown in the menu.

```
06=SPDIAL  ▶  
LINE  FA  DSS  SPDIAL
```

```
06=SPDIAL  ◀  
ACD  UNUSED
```



Select UNUSED.

```
06=UNUSED  ◀  
ACD  UNUSED
```

OK

Press the **OK** key to return to key selection. The key is converted to an Unused key.

Voice Mail Key

The **VOICE MAIL** key is used to speed dial a voice mail system.

*Note: The **VOICE MAIL** key must be programmed to dial the voice mail access number in order for this feature to work properly. "Smart" pauses and PIN codes can be included in the number.*

-  From the Installation Options menu, select KEYS.
(MENU → INSTL → KEYS)

-  Press the **VOICE MAIL** key.
The key's indicator will flash.

```
VOICE MAIL ACCESS
NUMBER
```

-  Select NUMBER to view or change the **VOICE MAIL** key speed dial number. This is the number that is dialed to access the voice mail system. The currently programmed dial string, if any, will be shown in the display.

```
NUMBER=
DELETE CLEAR 123 PAUSE
```

-  Enter the voice mail system number with the dial pad.
A # character at the end of the dial string is not required for immediate dialing; the voice mail key always dials immediately when pressed.

```
NUMBER=95551432P1234
DELETE CLEAR 123 PAUSE
```

-  "Smart" pauses are entered with the PAUSE softkey, and are shown in the display as a **P** character. The first pause in a dial string will wait until the call is answered; additional pauses delay dialing for one second per pause. Enter multiple pauses to increase the delay time. You can use a smart pause to automatically enter a voice mail PIN code after the voice mail system answers.

If you need to make corrections while entering numbers, press the Left or Right Arrow key to move the cursor position, and then select DELETE to delete the character under the cursor. CLEAR removes all digits, allowing you to start over.

-  When all digits have been entered, press the **OK** key.

Configuring the Speakerphone

The speakerphone can be configured with full speaker and microphone functionality, or with the microphone always muted (Call Monitoring). You can also completely disable the speakerphone.

On-hook dialing is available with the both speakerphone and Call Monitoring. Call Monitoring provides a listen-only call monitor function that is activated by the **SPEAKER** key.

When Call Monitoring is active, the indicators on the **SPEAKER** and **MUTE** keys are lit. Call progress tones, dialed digits, and the remote party can be heard through the built-in speaker, but you can only talk to the remote party with the handset or headset.



From the Installation Options menu, select KEYS.
(**MENU** → **INSTL** → **KEYS**)



Press the **SPEAKER** key.

```
SPEAKER=SPEAKERPHONE
PHONE  MON  DISABLE
```



Select **PHONE** to enable the speakerphone, **MON** to enable Call Monitoring, or **DISABLE** to disable the speakerphone and Call Monitoring.



Press the **OK** key twice to return to the Installation Options menu.

Call Timeout Options

These options set dialing, ringing, and reorder timeouts.

- From the Installation Options menu, select CALL.
(MENU → INSTL → ► → CALL)

```
CALL TIMEOUT OPTIONS
DIAL  RING REORDER
```

Dialing Timeout

- Select DIAL.

```
DIALING TIMEOUT SEC=10
DELETE CLEAR 123
```

- Enter the number of seconds (1-30) to wait after entering digits, before a call is automatically dialed without selecting SEND or pressing the **OK** key. Enter 0 or select CLEAR for no dialing timeout (automatic dialing after timeout is disabled).

Ringing Timeout

- Select RING.

```
RINGING TIMEOUT SEC=180
DELETE CLEAR 123
```

- Enter the number of seconds (1-300) that an incoming call will ring, before ringing is turned off and the call is abandoned. Enter 0 or select CLEAR for no ringing timeout (call continues to ring).

Reorder Timeout

- Select REORDER.

```
REORDER TIMEOUT SEC=180
DELETE CLEAR 123
```

- Enter the number of seconds (1-300) that the phone will remain in a disconnected or error state before the call is cleared. Enter 0 or select CLEAR for no reorder timeout (call remains in a disconnected or error state).

Installation PIN

You can set a PIN to prohibit unauthorized entry into the Installation Options menu. If a PIN is currently set, the display will prompt you to enter your PIN prior to making changes.

- From the Installation Options menu, select PIN.
(MENU → INSTL → ► → PIN)



INSTALLATION PIN
SET

- Select SET.



ENTER PIN: *****
BKSP CLEAR

- 5 JKL Enter a new 4 to 20 digit PIN with the dial pad.

If you need to make corrections, select BKSP (backspace) to delete the previous digit, or select CLEAR to remove all digits.

- OK Press the OK key.



VERIFY: *****
BKSP CLEAR

- 5 JKL Repeat the PIN when prompted to verify the new entry.

- OK Press the OK key.

“PIN SET” will be displayed to confirm the new PIN.



PIN SET

Record your PIN for future reference.

If you lose your PIN, you will no longer be able to access the Installation Options menu – contact Teo Technical Support for assistance.

- OK Press the OK key to return to the Installation Options menu or press the MENU key to exit Setup Mode.

Removing the PIN

To remove the Installation Options PIN, the phone must be reset. Refer to Reset to Factory Default Settings below.

Reset to Factory Default Settings

Reset returns all settings to the factory defaults, and clears all line IDs, server addresses, speed dial numbers, call logs, and PINs. The error log is not cleared.

This option is useful when moving the telephone to a new user or location.

- From the Installation Options menu, select RESET.
(MENU → INSTL → ► → RESET)

```
RESET ALL SETUP OPTIONS?  
YES  NO
```

- Select YES to confirm the reset operation.

```
ALL SETTINGS CLEARED  
PHONE WILL BE RESTARTED
```

```
INITIALIZING...
```

Updates

The telephone can be remotely configured, and its operating software updated, by several methods. Configuration and program updates can be stored on a Teo UC Server, or on a TFTP, HTTP, or HTTPS server. Updates can be scheduled to occur automatically at a fixed time each day or disabled. The update may be initiated manually using the START menu option.

The Installation Options menu can be protected by a PIN to prevent unauthorized updates (page 42).

Please refer to the [IP Telephone Network Administration Guide](#) for more information.

- From the Installation Options menu, select UPDATE.
(MENU → INSTL → ► → UPDATE)

```
IP CONFIGURATION UPDATE►
ADDR CONFIG PRGRM
```

- Select one of the update options.

ADDR (Phone IP Address Configuration)

```
ADDRESS CONFIG OPTIONS
IPV4  IPV6
```

IPv4 Addresses

- Select IPv4 to select the method used to set the phone IPv4 address.

```
ADDRESS IPv4=DHCPv4
DHCPv4  STATIC
```

- Select DHCPv4 to enable DHCP, STATIC to disable DHCP and use manually-entered IPv4 addresses, or OFF to disable IPv4 addressing (IPv6 protocol only) (page 21).

IPv4 Addresses

- Select IPv6 to select the method used to set the phone IPv6 address.

```
ADDRESS IPv6=OFF
AUTO6  STATIC  OFF
```

- Select OFF to disable IPv6 addressing (IPv4 protocol only), AUTO6 to enable stateless global IPv6 address auto configuration, or STATIC to use manually-entered Global IPv6 addresses (page 21).

The phone must be restarted to use the new IP address settings.

CONFIG (Configuration Updates)

This option updates the phone configuration.

```

CONFIG=TEO      AUTO=OFF
START  AUTO  PROTO

```

- Select PROTO to select the update server type: HTTPS, HTTP, or TFTP.

```

UPDATE PROTOCOL=TEO  ▶
TEO  TFTP  HTTP  HTTPS

```

```

UPDATE PROTOCOL=TEO  ▶
NONE

```

- To update the phone immediately, select START. The phone may restart after a successful configuration update.

The phone can be automatically updated from the server at a preset time.

- Select AUTO to change automatic update settings.

```

AUTO CFG TIME=03:00AM
DISABLE          AM/PM

```

- Enable or disable automatic updating as required.

- 5 JKL Enter the update time, in 12-hour format, with the dial pad. A leading "0" is required for hours 0-9. Select AM/PM as needed.

```

CONFIG=TEO      AUTO=ON
START  AUTO  PROTO

```

- OK Press the **OK** key when finished.

Teo IP Phone 4104 Installation Instructions

PRGRM (Program Updates)

This option updates the phone operating firmware. Phone operating firmware is digitally signed by Teo to ensure code validity. Modified operating firmware cannot be loaded into the phone.

```
PROGRAM=TEO    AUTO=ON
START  AUTO  PROTO
```

- Select PROTO to select the update server type: HTTPS, HTTP, TFTP, or NONE.

```
UPDATE PROTOCOL=TEO  ▶
TFTP  HTTP  HTTPS
```

```
UPDATE PROTOCOL=TEO  ▶
NONE
```

- To update the phone immediately, select START. The phone will restart after a successful program update.

The phone can be automatically updated from the server at a preset time.

- Select AUTO to change automatic update settings.

```
AUTO CFG TIME=03:00AM
DISABLE                AM/PM
```

- Enable or disable automatic updating as required.

- 5** JKL Enter the update time, in 12-hour format, with the dial pad. A leading "0" is required for hours 0-9. Select AM/PM as needed.

- OK** Press the **OK** key when finished.

PC Port

The built-in Ethernet switch and PC port allows a computer to share the phone's Ethernet connection.

```
PC PORT=ENABLED
ENABLE DISABLE
```

- Select ENABLE or DISABLE as needed.

Security Options

The security options allow you to control ARP monitoring, SRTP, SIP transport, and MLPP dialing. Leave these settings at the default values, unless changes are required for your network.

- From the Installation Options menu, select SECRTY.
(*SETUP* → INSTL → ► → SECRTY)

```
SECURITY OPTIONS
ARP  SRTP  TRANS  MLPP
```

ARP Monitoring

If your network does not monitor for Address Resolution Protocol (ARP) attacks, enable this option to turn on ARP monitoring in the phone.

- Select ARP.

```
ARP MONITORING=DISABLED
ENABLE DISABLE
```

- Select ENABLE or DISABLE as needed.

SRTP

Secure Real-time Transport Protocol (SRTP) is used to encrypt transmitted voice packets.

- Select SRTP.

```
SECURE RTP=DISABLED
ENABLE DISABLE
```

- Select ENABLE or DISABLE as needed.

Teo IP Phone 4104 Installation Instructions

SIP Transport

Defines the type of SIP transport used for SIP signaling.

- Select TRANS.

```
SIP TRANSPORT=UDP
UDP  TCP  TLS  TLS+
```

- Select UDP, TCP, TLS (uses SIP in the URI), or TLS+ (uses SIPS in the URI).

MLPP Dial Plan

Enables MLPP dialing and identifies the MLPP network domain. Note: This option may not appear if a custom dial plan has been configured through XML configuration download.

- Select MLPP.

```
MLPP DIALPLAN=DISABLED
DSN  UC  DISABLE
```

- Select DSN or UC network domain to enable MLPP, or DISABLE to disable MLPP dialing and preemption.

Viewing the Error Log

- From the Installation Options menu, select LOG.
(**MENU** → INSTL → ► → LOG)

```
VIEW LOG ENTRIES
ERROR  CLEAR
```

- Select ERROR to view the error log.
The most recent log entry will be shown.



Press the Down Arrow key to view previous entries, or press the Up Arrow key to return to newer entries.



Press the **OK** key to return to the View Log Entries menu or press the **MENU** key to exit Setup Mode.

Clearing the Error Log

- Select CLEAR to remove all entries from the error log.



Press the **OK** key to return to the Installation Options menu or press the **MENU** key to exit Setup Mode.

Administration Options

The following test and diagnostic options are available from the Administration Options menu:

- Local Inspect
- Hardware Version
- Software Version
- Serial Number
- Test Functions
- Diagnostics
- Phone Restart

Administration Options Menu

You can enter from the Administration Options menu when the phone is idle or during an active call.

 MENU

Press the **MENU** key.



```
SETUP MENU
INSTL ADMIN USER
```

 Select ADMIN.

```
ADMINISTRATION OPTIONS ►
INSPECT VERS TEST DIAG
```

 When ► appears in the upper line of the display, you can press the Left or Right Arrow key to see additional menu selections.

```
ADMINISTRATION OPTIONS ►
RESTART
```

Local Inspect

Local Inspect allows you to identify the Line ID or feature assignment of each configured key. You can use Local Inspect after key initialization to verify line appearance and feature assignments.



From the Administration Options menu, select INSPCT.
(**MENU** → ADMIN → INSPCT)

```
SELECT A KEY
```



Press the key that you want to inspect.
The key's indicator will alternately flash red and green.

The first two displayed digits are the key number. Additional displayed information will vary depending upon the key type, as shown below.

Line Appearance Key

The display will show the SIP Line ID (username) and SIP Display Name (CID) for the selected key.

```
01=LINE 4018  
Bessie Thompson
```

Feature Activator

The display will show the network feature activator number and service description for the selected key.

```
07=FEATURE ACTIVATOR  
CALL PARK
```

DSS/BLF Key

The display will show the first 17 digits of the monitored SIP Line ID (username) and the programmed autodial string.

```
05=DSS/BLF_PRES  
4251
```

Speed Dial Key

The display will show the programmed autodial string for the selected key.

```
08=SPEED DIAL  
9995552341
```



When you are finished inspecting keys, press the **OK** key to return to the Administration Options menu or press the **MENU** key to exit Setup Mode.

Version

Use this option to view the telephone's hardware versions, application software version, and serial number. This information can also be viewed by pressing the **INFO** key.

- From the Administration Options menu, select **VERS**.
(**MENU** → **ADMIN** → **VERS**)

```
VERSION
H/W  S/W  SERIAL
```

Hardware Version

- Select **H/W**.

```
MODEL: 4104
TOP:A PCB:A
```

Application Software Version

- Select **S/W**.

```
APP VERSION: 06.04.16
```

Serial Number

- Select **SERIAL**.

```
SERIAL#: 00379196001
```



Press the **OK** key to return to the Administration Options menu or press the **MENU** key to exit Setup Mode.

Test

Select this option to test the LCD display, LED indicators, and keys.

-  From the Administration Options menu, select TEST.
(MENU → ADMIN → TEST)



```
TERMINAL TEST
DISPLY KEYS
```



Display and LED Indicators

-  Select DISPLY.







```
DISPLAY/LED TEST
LCD  RED  GREEN  OFF
```

LCD Display

-  Select LCD.
All pixels (picture elements, or dots) on the display should turn dark.
-  Press any key to return the display to normal operation.

LED Indicators



-  Select RED to turn on all red indicators, and turn all others off.
-  Select GREEN to turn on all green indicators, and turn all others off.
-  Select OFF to turn off all indicators, or wait 5 seconds for automatic off.
-  Press the **OK** key to return to the Terminal Test menu or press the **MENU** key to exit Setup Mode.

Keys

-  Select KEYS.



```
PRESS EACH KEY TO TEST
OR GO OFF-HOOK TO EXIT
```

-  Press each key on the telephone, including the dial pad keys, one at a time.
-  A letter should appear in the display for each pressed key.



"A" is shown in the upper left corner of the display after the first keypress, to fill out the 48-character display. The 4104 has 47 keys.

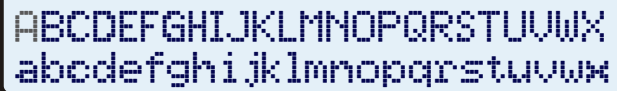

```
ABCDEFGHIJKLMN OPQRSTU VWX  
abcdefghijklmnopqrstu vw
```

If all keys are operational, the following display will be shown. Press any key to return to the Terminal Test menu.



```
KEY TEST PASSED  
PRESS ANY KEY TO EXIT
```

If any key fails, or to exit before testing all keys, go off-hook with the handset or unplug the phone.

Diagnostic Displays

- From the Administration Options menu, select DIAG.
(MENU → ADMIN → DIAG)

```
DIAGNOSTIC OPTIONS
LINK PACKET PING
```

Link

- Select LINK to determine which SIP lines are registered after phone initialization. Registered lines will light green; unregistered lines will light red.

Packet Statistics

- Select PACKET to view packet reception statistics for an active call, or the last 50 recorded call statistics. Refer to the [IP Telephone Network Administration Guide](#) for a detailed description of packet statistics.

```
PACKET STATISTICS
ACTIVE          HISTORY
```

- Select ACTIVE to view packet reception statistics for the current call. This option can be viewed only during an active call.

```
G.711/20ms JTR=10/100ms ▶
ACTIVE CALL
```

- Press the Right Arrow key to view additional statistics.

- From the Packet Statistics menu, select HISTORY to view the last 50 recorded packet reception statistics.

```
JITTER DELAY=10ms ▶
HISTORY
```

- When ▶ appears in the upper line of the display, you can press the Left or Right Arrow key to see additional menu selections.
Press the Right Arrow key to view additional statistics.

Ping

- Select PING to verify the path to an IP address.

```
SELECT DEVICE TO PING ▶
PHONE GATEWAY UPDT PROXY
```

```
SELECT DEVICE TO PING ▶
SNTP DHCP REGSTR OTHER
```

- Select a device to ping.

Or, select OTHER, enter an IP address or server name, and then select PING.
Character entry is explained on page 14.

```
OTHER=
DELETE CLEAR PING
```

The display will show the result of the ping test.

```
PING4 SUCCESSFUL
PRESS ANY KEY TO EXIT
```

```
PING4 FAILED
PRESS ANY KEY TO EXIT
```

- Press any key to return to the Ping menu.



When finished, press the **OK** key to return to the Diagnostic Options menu or press the **MENU** key to exit Setup Mode.

Restarting the Phone

Select Restart to reset the phone. If you are on an active call you will be disconnected. The call log will be cleared. No configuration parameters will be altered, and the error log will not be cleared.

- From the Administration Options menu, select RESTART.
(MENU → ADMIN → ► → RESTART)



```
RESTART?  
YES     NO
```

- Select YES to restart the phone.

Troubleshooting

4104 telephones have built-in diagnostic and testing capabilities to quickly isolate problems affecting their operation.

Power-up & Connection Troubleshooting

Whenever power is applied or a connection is made to the LAN or WAN, the phone initiates a startup routine, with progress shown in the display. When the phone and network are fully initialized, the idle display, indicating date and time, will be shown. In cases where full initialization is not attained, the following displays or conditions will be shown continuously until corrected.

Problem Observed	Remedial Action
<i>No display information is shown</i>	Check power connections and source, or verify connection to 802.3af-compatible PoE power source.
NO ETHERNET CONNECTION	Check connections to the LAN or WAN.
LINE ID= DELETE CLEAR 123	The Line ID is a null value. Enter the appropriate Line ID number.
DHCPv4 ERROR. RETRYING PRESS MENU TO CONFIGURE	Verify that the DHCP server is operating and accessible. If the LAN or WAN does not include a DHCP server, disable IP configuration via DHCP and enter the appropriate IP values (phone, default gateway, subnet mask, update) using the INSTL→IP Menu.
IP4 ADDR=000.000.000.000 EDIT	The phone IP address is a null value. Enter the appropriate phone IP address or name, or change the IP Configuration Update IPv4 address from STATIC to IPv4 to allow the DHCP server to assign an address to the telephone.
GATEWAY= EDIT	The default gateway IP address is a null value. Enter the appropriate gateway IP address or server name.
SUBNET=000.000.000.000 EDIT	The subnet mask is a null value. Enter the appropriate subnet mask.
UPDATE= EDIT	The update server IP address is a null value. Enter the appropriate update server IP address or server name.
AUTH ID= DELETE CLEAR 123	The AUTH ID is a null value. Enter the appropriate AUTH ID.
AUTH PSWD= DELETE CLEAR 123	The AUTH PSWD (password) is a null value. Enter the appropriate AUTH password.

Teo IP Phone 4104 Installation Instructions

Problem Observed	Remedial Action
PROXY= DELETE CLEAR 123	The Proxy server address is a null value. Enter the appropriate Proxy server IP address or server name.
REGISTERING LINES	The primary line has not registered with the SIP server. Verify all entries (LINE ID, AUTH ID, AUTH Password, all IP addresses and subnet mask) and re-enter as required.
REGISTERING LINES CONTINUE	The primary line has registered with the SIP server; however, additional lines have not. Verify the LINE ID, AUTH ID and AUTH passwords for all additional lines and re-enter as required.
RESTART WITH NEW VALUES? YES NO	Certain critical values have changed and a restart is required. Select YES.
PHY:100MBPS IP:DHCP FAIL	Upon lease expiry, the phone was unable to negotiate a new lease with the DHCP server. Verify that the DHCP server is operating and accessible.
PING4 FAILED PRESS ANY KEY TO EXIT	If all attempts to ping IP addresses fail, check Layer 2 802.1Q (VLAN) programming at the phone, using the QoS menu. If "LAYER 2 802.1Q=ON", verify that the network supports this packet prioritization standard. If it does not, set LAYER 2 802.1Q to "OFF". Ping valid addresses using the ADMIN→DIAG→PING Menu.

Call Control Troubleshooting

After the phone is fully initialized (idle display showing), the following call control anomalies may be encountered.

Problem Observed	Remedial Action
All lines indicate the arrival of inbound calls via the key indicators; however, the phone does not ring for some of them.	Verify that the affected lines are not set for NEVER or an extended WAIT interval, using the USER→RING→CONTROL Menu. If this behavior is not desired, change the value of the attribute to "ALWAYS" where applicable.
All lines indicate the arrival of inbound calls via the key indicators; however, the phone never rings.	Verify that "RINGER OFF" is not showing in the display. If it is, use the Volume key to set the ringer level to a value higher than OFF.

Diagnostic Troubleshooting

After the phone is fully initialized (idle display showing), the following diagnostic information may be reviewed, using the ADMIN→DIAG Menu.

Diagnostic Mode	Information Provided
<p>LINK option selected:</p>	<p>The LINK option provides information about the network and SIP server status as follows:</p> <p>1) Status about the network will be displayed:</p> <pre>PHY:100MBPS IP:AUTO OK</pre> <p><i>(DHCP used for IP addressing at phone)</i></p> <p style="text-align: center;"><i>or</i></p> <pre>PHY:100MBPS IP:NO AUTO</pre> <p><i>(DHCP is enabled, and has not completed successfully)</i></p> <p style="text-align: center;"><i>or</i></p> <pre>PHY:100MBPS IP:STATIC</pre> <p><i>(DHCP is disabled, fixed IP addresses are in use at phone)</i></p> <p>2) Registration status for each line will be indicated via line status LED for 2 seconds.</p> <p>Solid Green – Line registration successful with server.</p> <p>Alternating red/green – Line registration in process and un-determinate.</p> <p>Solid Red – Line registration failed.</p> <p>Flashing red – The primary line is active, and secondary line(s) are not registered.</p>
<p>PACKET option selected:</p> <p>and then ACTIVE option selected:</p>	<p>The PACKET option allows the selection of statistics for the current active call (ACTIVE) or a standing aggregate of previous calls (HISTORY).</p> <p>Status indicating the negotiated codec, the received packetization rate and the real-time jitter buffer setting is displayed for the current call as below:</p> <pre>G.711/30ms JTR=XX/YYYms▶</pre> <pre>ACTIVE CALL</pre> <p>Selecting the Right Arrow key in succession will indicate additional status information as below:</p> <p>Total number of concealed packets (lost or delayed)</p> <p>Total number of lost packets (expected, not-received)</p> <p>Total number of not-delayed packets (<10mS delay)</p>

Diagnostic Mode	Information Provided
<p>or HISTORY option selected:</p>	<p>Total number of packets delayed more than 10mS Total number of packets delayed more than 20mS Total number of packets delayed more than 30mS Total number of packets delayed more than 40mS Total number of packets delayed more than 50mS Total number of packets delayed more than 60mS Total number of packets delayed more than 70mS Total number of packets delayed more than 80mS Total number of jitter buffer underflow events Total number of jitter buffer overflow events Total number of expected packets (received and not received)</p> <p>Status for the current “start of call” average jitter buffer setting for either fixed or calculated, adaptive delay for the primary line.</p> <pre>JITTER DELAY=XXms ▶ HISTORY</pre> <p>Selecting the Right Arrow key in succession will indicate additional status information as below:</p> <p>Total number of concealed packets (lost or delayed) Total number of lost packets (expected, not-received) Total number of not-delayed packets (<10mS delay) Total number of packets delayed more than 10mS Total number of packets delayed more than 20mS Total number of packets delayed more than 30mS Total number of packets delayed more than 40mS Total number of packets delayed more than 50mS Total number of packets delayed more than 60mS Total number of packets delayed more than 70mS Total number of packets delayed more than 80mS Total number of jitter buffer underflow events Total number of jitter buffer overflow events Total number of expected packets (received and not received)</p>

Diagnostic Mode	Information Provided
<p>PING option selected:</p>	<p>The PING option provides the means for measuring single packet network delays.</p> <p>The following IP addresses may be “pinged”:</p> <p>PHONE GATEWAY UPDATE SERVER SIP PROXY SERVER SNTP SERVER DHCP SERVER SIP REGISTRAR SERVER OTHER*</p> <p><i>*A valid address must also be entered.</i></p> <p>There are three outcomes as the result of a ping:</p> <p style="text-align: center;">IP ADDRESS NOT SET</p> <p><i>In this case enter the appropriate IP address, using the INSTL/IP Menu.</i></p> <p style="text-align: center;"><i>or</i></p> <p>PING4 FAILED PRESS ANY KEY TO EXIT</p> <p><i>In this case, check Layer 2 802.1Q and other network settings.</i></p> <p style="text-align: center;"><i>or</i></p> <p>PING4 SUCCESSFUL PRESS ANY KEY TO EXIT</p>

Teo IP Phone 4104 Installation Instructions

Appendix A

Setup Menu Tree

INSTL (*Installation Options – PIN Protected*)

IP (*Internet Protocol Addresses*) page 20

PHONE (*Phone IP Address*)

IPv4 (*Internet Protocol version 4 Address*)

EDIT

PING4

IPv6 (*Internet Protocol version 6 Addresses*)

LINK (*Link-Local Address*)

GLBL1 (*Global Address*)

VIEW

EDIT

REM (*Remove Global Address*)

PING6

ADD (*Add Global Address*)

SUBNET (*Phone IPv4 Subnet Mask*)

EDIT

GATEWY (*Gateway IPv4 Address*)

EDIT

PING4

DNS (*Domain Name Server Address*)

EDIT

PING4

CFG (*DNS IP Address Configuration*)

DHCP4

STATIC

UPDATE (*Update Server Address*)

EDIT

PING4

CFG (*Update Server IP Address Configuration*)

DHCP4

STATIC

SNTP (*Simple Network Time Protocol Server Address*)

EDIT

DHCP4

STATIC

OPTION

OFFSET (*Time Offset from UTC*)

DSTADJ (*Daylight Savings Time Adjustment*)

PING4

CFG (*SNTP Server IP Address Configuration*)

DHCP4

STATIC

Teo IP Phone 4104 Installation Instructions

SYSLOG (*Logging Server Address*)

EDIT

OPTION

NONE (*Disable Syslog Messages*)

BASIC (*Record Error Logs*)

QoS (*Record Error Logs and QoS statistics*)

CFG (*Syslog Server IP Address Configuration*)

DHCP4

STATIC

MAC (*Ethernet MAC Address*)

SIP (*Session Initiation Protocol Settings*) page 25

PHONE (*SIP Phone Configuration*)

DOMAIN (*Phone Domain Name*)

PORT (*Phone SIP Port Number*)

RTP (*Phone RTP Start Port Number*)

PROXY (*SIP Proxy*)

ID (*SIP Proxy Server Name or IP Address*)

PORT (*SIP Proxy Server Port Number*)

REGSTR (*SIP Registration*)

ENABLE

ENABLE (*Enable SIP Registration*)

DISABLE (*Disable SIP Registration*)

ID (*SIP Registrar Name or IP Address*)

PORT (*SIP Registrar Port Number*)

MWI (*Message Summary Event Subscription for MWI*)

OFF

ON

QoS (*Quality of Service Options*) page 30

L2 (*Layer 2 801.2Q*)

OFF/ON

PHONE

VOICE (*Voice Packet Priority*)

SIGNAL (*Signaling Packet Priority*)

ID (*Phone VLAN ID*)

PC

CLEAR

NONE

L3 (*Layer 3 DiffServ*)

VOICE (*Voice Differentiated Services Code Point*)

SIGNAL (*Signaling Differentiated Services Code Point*)

KEYS

LINE (*Line Appearance Key*) page 32

- ID** (*SIP Line ID*)
- NAME** (*Display Name*)
- AUTHID** (*SIP Authentication ID*)
- PSWD** (*SIP Authentication Password*)
- SHARE** (*Bridged Line Appearance*)
 - ENABLE**
 - DISABLE**
- VA** (*Voice Announce*)
 - ENABLE**
 - DISABLE**
- CODEC** (*Codec 1, 2, or 3*)
 - CODEC** (*Codec Type*)
 - G.711**
 - G.729A**
 - G.722**
- PTIME** (*Packetization Time*)
 - TIME+**
 - TIME-**
- JTR** (*Jitter Buffer Type and Settings*)
 - When **FIXED** is selected:
 - DLY+**
 - DLY-**
 - ADAPT** (*Adaptive Jitter Buffer Delay*)
 - When **ADAPT** is selected:
 - DELAY**
 - MIN+**
 - MIN-**
 - MAX+**
 - MAX-**
 - FIXED** (*Fixed Jitter Buffer Delay*)
- ADD** (*Add Line Appearance to Group*)
- REMOVE** (*Remove Highest-Numbered Line Appearance in Group*)
- LABEL** (*Idle Screen Label, set on Line Appearance 1 only*)
- AA** (*Auto Answer*)
 - DISABLE** (*No Auto Answer*)
 - 2WAY** (*Answer with Microphone Enabled*)
 - MUTE** (*Answer with Microphone Disabled*)

FA (*Feature Activator*) page 35

Teo IP Phone 4104 Installation Instructions

DSS (<i>Direct Station Select/Busy Lamp Field</i>)	page 36
ID (<i>SIP Line ID</i>)	
NAME (<i>Caller ID Name</i>)	
AUTHID (<i>SIP Authentication ID</i>)	
PSWD (<i>SIP Authentication Password</i>)	
TYPE (<i>SIP Event Type</i>)	
PRES (<i>Event: presence</i>)	
DIALOG (<i>Event: dialog</i>)	
DLGSLA (<i>Event: dialog;sla</i>)	
DSS# (<i>DSS Speed Dial Number</i>)	
SPDIAL (<i>Speed Dial</i>)	page 37
ACD (<i>Automatic Call Distribution</i>)	page 38
ID (<i>Group ID</i>)	
UNUSED	page 38
Voice Mail Key (<i>Press VOICE MAIL key for this menu</i>):	page 39
NUMBER (<i>Speed Dial Number</i>)	
Speaker Options (<i>Press SPEAKER key for this menu</i>):	page 40
PHONE (<i>Speakerphone</i>)	
MON (<i>Call Monitor; Microphone Disabled</i>)	
DISABLE (<i>Speakerphone and Call Monitor Disabled</i>)	
CALL (<i>Call Timeout Options</i>)	page 41
DIAL (<i>Dialed Digits Timeout</i>)	
RING (<i>Ringling Timeout</i>)	
REORDER (<i>Reorder Timeout</i>)	
PIN (<i>Installation Options PIN</i>)	page 42
SET (<i>Add or Change PIN</i>)	
RESET (<i>Reset to Default Settings</i>)	page 42
UPDATE (<i>Configuration and Program Updates</i>)	
ADDR (<i>Phone IP Address Configuration</i>)	page 44
IPv4	
DHCPv4	
STATIC	
OFF (<i>IPv6 only</i>)	
IPv6	
AUTO6	
STATIC	
OFF (<i>IPv4 only</i>)	
CONFIG	page 45
START (<i>Start Configuration Update</i>)	
AUTO (<i>Automatic Update Settings</i>)	
PROTO (<i>Update Server Protocol</i>)	
TEO	
TFTP	
HTTP	
HTTPS	
NONE	

PRGRM page 46

- START** *(Start Program Update)*
- AUTO** *(Automatic Update Settings)*
- PROTO** *(Update Server Protocol)*
 - TEO**
 - TFTP**
 - HTTP**
 - HTTPS**
 - NONE**

PC PORT *(Ethernet Port for PC)* page 47

- ENABLE**
- DISABLE**

SECRTY *(Security Options)* page 47

- ARP** *(ARP Monitoring)*
 - ENABLE**
 - DISABLE**
- SRTP** *(Secure Real-time Transport)*
 - ENABLE**
 - DISABLE**
- TRANS** *(SIP Transport Protocol)*
 - UDP**
 - TCP**
 - TLS**
 - TLS+**
- MLPP** *(MLPP Dial Plan)*
 - DSN**
 - UC**
 - DISABLE**

LOG *(Error Log)* page 48

- ERROR** *(View Error Log)*
- CLEAR** *(Clear Error Log)*

Teo IP Phone 4104 Installation Instructions

ADMIN *(Administration Options)*

INSPECT <i>(Local Inspect)</i>	page 50
VERS <i>(Version)</i>	page 51
H/W <i>(Hardware Versions)</i>	
S/W <i>(Software Version)</i>	
SERIAL <i>(Serial Number)</i>	
TEST	page 52
DISPLY <i>(Display and Indicators)</i>	
LCD <i>(Test LCD Display)</i>	
RED <i>(Test Red Indicators)</i>	
GREEN <i>(Test Green Indicators)</i>	
OFF <i>(Turn All Indicators Off)</i>	
KEYS <i>(Test Phone Keys)</i>	
DIAG <i>(Diagnostic Display)</i>	page 54
LINK <i>(Connection Status)</i>	
PACKET <i>(Packet Reception Statistics)</i>	
ACTIVE <i>(Current Active Call)</i>	
HISTORY <i>(Previous 50 Statistics)</i>	
PING <i>(Ping Message to Server or IP Address)</i>	
PHONE <i>(This Telephone)</i>	
PING <i>(Repeat Ping)</i>	
GATEWAY <i>(Gateway)</i>	
PING <i>(Repeat Ping)</i>	
UPDT <i>(Update Server)</i>	
PING <i>(Repeat Ping)</i>	
PROXY <i>(Proxy Server)</i>	
PING <i>(Repeat Ping)</i>	
SNTP <i>(SNTP Time Server)</i>	
PING <i>(Repeat Ping)</i>	
DHCP <i>(DHCP Server)</i>	
PING <i>(Repeat Ping)</i>	
REGSTR <i>(SIP Registration Server)</i>	
PING <i>(Repeat Ping)</i>	
OTHER	
CLEAR <i>(Clear IP Address)</i>	
PING <i>(Initiate/Repeat Ping)</i>	
RESTART <i>(Restart Phone and Clear Call Log)</i>	page 56

USER *(User Options)*

Options in this menu are described in the [IP Phone 4104 User Guide](#).

CLOCK *(Set Time and Date)*

KEYS *(Speed Dial Keys)*

NUMBER *(Dial String)*

DELETE *(Delete Character)*

PAUSE *(Dialing Pause)*

123/ABC/abc *(Character Entry Mode)*

DIR *(Call Directory)*

BKSP *(Delete Character)*

CLEAR *(Clear Entry)*

MOVE *(Move Entry to New Location)*

NUMBER *(Edit Dial String)*

DELETE *(Delete Character)*

NAME *(Directory Name Entry)*

123/ABC/abc *(Character Entry Mode)*

RING *(Personal Ringing)*

tone *(Ringing Tone)*

ALL *(All Keys use the same Ringing Tone)*

OFFHK *(Off-Hook Ringing)*

NORMAL

SINGLE *(Single Burst)*

CONTRL *(Ringing Control)*

ALWAYS *(Ring Immediately)*

NEVER *(Never Ring)*

WAIT2 *(Wait 2 Ring Cycles / 12 seconds)*

WAIT3 *(Wait 3 Ring Cycles / 18 seconds)*

WAIT4 *(Wait 4 Ring Cycles / 24 seconds)*

WAIT5 *(Wait 5 Ring Cycles / 30 seconds)*

WAIT6 *(Wait 6 Ring Cycles / 36 seconds)*

WAIT7 *(Wait 7 Ring Cycles / 42 seconds)*

LCFWD *(Local Call Forward No Answer Delay)*

DELETE *(Delete Character)*

CLEAR *(Clear Label)*

Teo IP Phone 4104 Installation Instructions

VOICE *(Handset/Headset Options)*

MODE *(Voice Mode)*

HAND *(Handset)*

HEAD *(Headset)*

VOLUME

HAND *(Handset)*

RCV+/- *(Receive Volume Up/Down)*

XMT+/- *(Transmit Volume Up/Down)*

HEAD *(Headset)*

RCV+/- *(Receive Volume Up/Down)*

XMT+/- *(Transmit Volume Up/Down)*

SPKR *(Speakerphone)*

XMT+/- *(Transmit Volume Up/Down)*

RESET *(Reset to Default Volume Levels)*

DISPLY *(Display Contrast)*

+ *(Increase Contrast)*

- *(Decrease Contrast)*

PIN *(Call Log PIN)*

SET *(Set New PIN)*

CLEAR *(Remove PIN)*

Appendix B

Service and Warranty

Service

The Teo 4104 has no user-serviceable parts inside; repair must be done by Teo.

Prior to equipment removal, call Teo Customer Technical Support for assistance in determining the source of the problem. This critical action can often prevent needless removal of equipment and subsequent customer inconvenience.

Teo
Technical Support Department
11609 49th Place West
Mukilteo, WA 98275-4255 USA

Phone: (425) 349-1000
(800) 524-0024

Fax: (425) 349-1010

E-mail: tech@teotech.com

Web: www.teotech.com

Teo is committed to meeting the product needs of our customers. Please write or call us with any suggestions for improvement.

Teo Product Warranty

For a period of one year from date of dealer purchase, but not to exceed 16 months from date of manufacture, Teo Technologies, Inc. (Teo) warrants its products to be free from defects in material and workmanship under conditions of normal use and service. Teo shall, at its option, repair or replace any defective product which, in its opinion, has not been misused, damaged, or improperly installed.

Repair or replacement under this warranty will be performed at Teo's factory. Authorization must be obtained from Teo prior to returning a product for repair. Freight must be prepaid for all units returned to Teo. Units repaired under warranty will be shipped UPS Ground (or equivalent), freight prepaid by Teo.

Products that are older than the warranty period, but less than 7 years old, or still manufactured by Teo may be repaired at the factory for a flat rate charge. Repaired out-of-warranty units are warranted for 90 days from the date of repair.

The repair or replacement of a product under this warranty represents the entire obligation of Teo; Teo shall not be liable for any special or consequential damages resulting from or caused by any defect, failure, incapacity or malfunction of any of its products.

The foregoing express warranty is in lieu of all other warranties, express or implied, including but not limited to any implied warranty of merchantability, fitness, or adequacy for any purpose or use, quality, productiveness or capacity; Teo, to the extent permitted by law, hereby disclaims all such other warranties.

Appendix C

Specifications

Contents of Shipping Container

- Telephone + Stand
- Handset
- Modular handset coil-cord
- Ethernet cable
- Base retainer screws for wall mounting
- Documentation CD

Standards Compliance

- FCC Part 15
- Hearing Aid Compatible
- CE Listed

Network Compatibility

- 10BaseT and 100BaseT Ethernet

Power Requirements

- Power over Ethernet: 802.3af Class 2
- Optional Local Power: 12 VDC nominal @ 1 A max.

Physical Dimensions

- 9.6" W x 7.3" D x 3.3" H, excluding handset

Weight

- 2.2 lbs., including stand and handset

Environmental

- Operating Temperature: 32° to 104° F (0° to 40° C)
- Storage Temperature: 32° to 122° F (0° to 50° C)
- Humidity: 5% to 95% non-condensing

Teo IP Phone 4104 Installation Instructions

Appendix D

Regulatory Statements



Important Safety Instructions

1. Read the installation instructions before connecting the system to its power source.
2. Installation of equipment must not route interconnecting cables or external power supply sources outdoors. This is defined as "Network Environment 0" by IEC TR 62101.
3. Never install network jacks in wet locations unless the jacks are specifically designed for wet locations.
4. Never touch uninsulated wires or terminals.
5. Do not connect this product to telephone network voltage (TNV) circuits. Some LAN and WAN ports both use RJ-45 connectors. Use caution when connecting cables.

When using your telephone equipment, basic safety precautions should always be followed to reduce the risk of fire, electric shock and injury to persons, including the following:

6. Read and understand all instructions.
7. Follow all warnings and instructions marked on the product.
8. Unplug all cables before cleaning. Do not use liquid or aerosol cleaners. Use a damp cloth for cleaning.
9. Do not use this product near water, for example, near a bathtub, wash bowl, kitchen sink, or laundry tub, in a wet basement, or near a swimming pool.
10. Do not place this product on an unstable cart, stand, or table. The product may fall, causing serious damage to the product.
11. This product should be operated only from the type of power source indicated on the marking label.
12. Do not allow anything to rest on the power cord. Do not locate this product where the cord will be abused by persons walking on it.
13. Do not overload wall outlets and extension cords as this can result in the risk of fire or electric shock.
14. This product contains "No User-Serviceable Parts."
15. Unplug this product from the wall outlet and refer servicing to qualified service personnel under the following conditions:
 - A. When the power supply cord or plug is damaged or frayed.
 - B. If liquid has been spilled into the product.
 - C. If the product has been exposed to rain or water.
 - D. If the product does not operate normally by following the operating instructions. Adjust only those controls that are covered by the operating instructions, because improper adjustment of other controls may result in damage and will often require extensive work by a qualified technician to restore the product to normal operation.
 - E. If the product has been dropped or the case has been damaged.
 - F. If the product exhibits a distinct change in performance.

SAVE THESE INSTRUCTIONS

FCC Requirements

The Teo 4104 is hearing-aid compatible (HAC) per Section 68.316, FCC Rules and Regulations.

This equipment has been tested and found to comply with the limits for a Class A digital device, pursuant to Part 15 of the FCC Rules. These limits are designed to provide reasonable protection against harmful interference when the equipment is operated in a commercial environment. This equipment generates, uses, and can radiate radio frequency energy and, if not installed and used in accordance with the instruction manual, may cause harmful interference to radio communications. Operation of this equipment in a residential area is likely to cause harmful interference in which case the user will be required to correct the interference at their own expense.